

Application Guidelines for Non-Isolated Converters

AN04-003 Remote On/Off Considerations

Introduction

The remote On/Off pin allows the user to switch the module on or off remotely via a system generated signal. Usually, this is a logic level signal referenced to the converter's ground pin. This feature provides greater flexibility in the start-up or shutdown sequencing and/or fault control of the user's power system. This application note outlines the types of remote ON/Off circuits, and provides helpful design tips on the utilization of this feature. For applications requiring simultaneous start-up or voltage tracking, consult **Application Note AN04-008** titled "**Application Guidelines for Non-Isolated Converters: Sequencing Recommendations**".

Types of Remote On/Off Controls

Most non-isolated converters are available in **Positive Logic** and/or **Negative Logic** versions for Remote On/Off.

Positive Logic devices turn the module on during a logic High on the On/Off pin and off during a logic Low. When not using the Positive logic On/Off pin, leave the pin unconnected or tie to Vin.

Negative Logic devices turn the module on during a logic Low on the On/Off pin and off during a logic High. When not using the Negative logic On/Off pin, leave the pin unconnected or tie to GND.

Note: Even though the data sheets allow the On/Off pins to be left unconnected, it is good design practice to tie the pins to Vin (for Positive Logic devices) and to GND (for Negative Logic devices) in order to ensure that the module will not turn on/off unintentionally due to noise spikes that could be generated under line transient conditions such as when the input is hot plugged-in or "hard" turned on or in the presence of noisy input line and ground.

Table 1 below is a summary of the common logic levels and the resulting module output states.

Table 1

On/Off Logic State	Negative Logic Devices	Positive Logic Devices
Open	Module On	Module On
Low or Pin tied to GND	Module On	Module Off
High or Pin tied to Vin(+)	Module Off	Module On

Table 2 shows a cross-reference for naming conventions and the availability of codes with the different logic types.

Note that all TLynx series modules are available in both positive and negative logic versions. The Naos Raptor series of modules all have positive on/off logic.

Table 2

Code Family	Negative Logic	Positive Logic
Austin Lynx II Series		
Austin MicroLynx II SMT	ATH006A0X -SR	ATH006A0X4 -SR
Austin MicroLynx II SIP	ATH006A0X	ATH006A0X4
Austin Lynx II SMT	ATH010A0X3 -SR	ATH010A0X43 -SR
Austin Lynx II SIP	ATH010A0X3	ATH010A0X43
Austin SuperLynx II SMT	ATH016A0X3 -SR	ATH016A0X43 -SR
Austin SuperLynx II SIP	ATH016A0X3	ATH016A0X43
12V Austin MicroLynx II SMT	ATA006A0X -SR	ATA006A0X4 -SR
12V Austin MicroLynx II SIP	ATA006A0X	ATA006A0X4
12V Austin Lynx II SMT	ATA010A0X3 -SR	ATA010A0X43 -SR
12V Austin Lynx II SIP	ATA010A0X3	ATA010A0X43
12V Austin SuperLynx II SMT	ATA016A0X3 -SR	ATA016A0X43 -SR
12V Austin SuperLynx II SIP	ATA016A0X3	ATA016A0X43
Austin Lynx Series		
Austin MicroLynx SMT	AXH005A0X -SR	Not available
Austin MicroLynx SIP	AXH005A0X	Not available
Austin Lynx SMT	Not available	AXH010A0x -SR (1)
Austin Lynx SIP	AXH010A0x (1)	Not available
Austin SuperLynx SMT	Not available	AXH016A0X3 -SR
Austin SuperLynx SIP	AXH016A0X3	Not available
12V Austin MicroLynx SMT	AXA005A0X -SR	Not available
12V Austin MicroLynx SIP	AXA005A0X	Not available
12V Austin Lynx SMT	Not available	AXA010A0X3 -SR
12V Austin Lynx SIP	Not available	AXA010A0X3
12V Austin SuperLynx SMT	Not available	AXA016A0X3 -SR
12V Austin SuperLynx SIP	Not available	AXA016A0X3

Notes: (1) x denotes voltage code (see data sheet)

Remote On/Off Implementation

In order to turn the module on or off, an external switch (signal NPN or N-Channel FET) is typically used to interface with the On/Off pin. It is important to review and adhere to each module's On/Off electrical specifications as described in the features table of the data sheet. The following design recommendations are a general guide to implementation.

Positive Logic Modules:

For positive logic modules, the circuit configuration for using the On/Off pin is shown in Fig. 1.

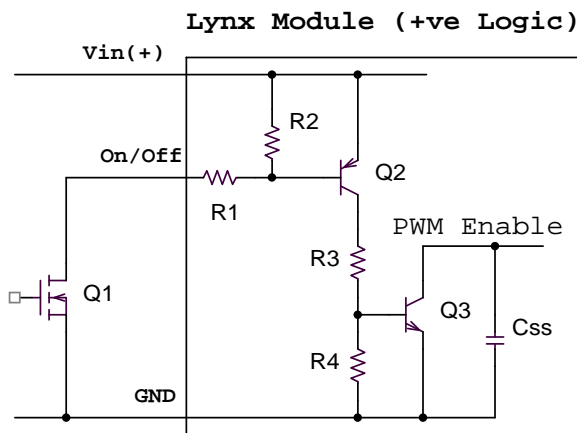

Fig. 1 Circuit configuration for using Positive Logic

NOTE: Q1 can be a N-Channel logic level FET such as FDN337N or a general purpose NPN transistor such as MMBT2222A.

When Q1 is in the off state, the On/Off pin is pulled high internally and the module is ON.
 When Q1 is turned on, the ON/Off pin goes low turning the module off.

Negative Logic Modules:

For negative logic modules, the circuit configuration for using the On/Off pin is shown in Fig. 2. When Q1 is in the off state, the On/Off pin is pulled high with the external Rpull-up resistor and the module is OFF. When Q1 is turned on, the ON/Off pin goes low turning the module ON.

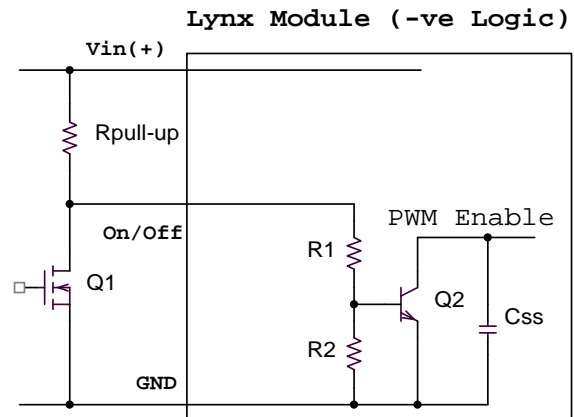

Fig. 2 Circuit configuration for using Negative Logic On/Off

NOTE:

Rpull-up = 5Kohms (+/- 5%) for 3.3/5Vin modules

Rpull-up = 68Kohms (+/- 5%) for 12Vin modules.

As before, Q1 can be a N-Channel logic level FET such as FDN337N or a general purpose NPN transistor such as MMBT2222A.

Using The On/Off Pin for Sequential Start-up of Multiple Modules – A Design Example

The On/Off pin can be used to implement sequential start-up of two or more modules. This may be desirable in situations where the load may need to be powered up with voltages in a particular order or in situations where the currents provided by a source converter need to be limited by avoiding simultaneous turn-on of all the downstream units. For applications requiring simultaneous start-up or voltage tracking for the Austin LynxII series, please refer to **Application Note AN04-008** titled "**Application Guidelines for Non-Isolated Converters: Sequencing Recommendations**".

In this example, the output from the one module acts as the input signal for the On/Off pin of the next module to be turned on. This is illustrated by the following design example.

Design Requirements:

1. The system consists of 3 modules; 12Vin/3.3Vo Austin SuperLynx (+ve Logic), 12Vin/1.8Vo Austin SuperLynx (+ve Logic) and a 3.3Vin/2.5Vo Austin MicroLynx (-ve Logic). The last unit is powered from the first unit.
2. The sequencing requirements are in the same order as the module configuration mentioned above.
3. A certain amount of delay is desirable between the start-up of each succeeding unit.

Design Implementation:

1. The 12Vin is applied and the 3.3Vo unit is allowed to come up first per the sequencing requirements; the remainder of the 2 modules are kept in an off mode.
2. The 3.3Vo is used as a signal to a time delayed On/Off interface circuit (see Fig. 3) that turns on the 1.8Vo unit. The 2.5Vo unit remains off.
3. Lastly, the 1.8Vo is then used as a signal to another time delayed On/Off interface circuit (see Fig. 4) for the 2.5Vo uLynx.
4. See Turn-On Interface circuits below.

Circuit Details: See Fig. 3 for Turn-On Interface circuit for positive Logic modules and Fig. 4 for negative Logic modules.

Circuit Description: The turn-on input signal for this interface circuit is 3.3V that is the output of the previous unit (12Vin/3.3Vo). The resistor combination of R1 & R2 acts as a voltage divider to set up the turn-on drive voltage for the selected transistor. For most signal level devices, this should be between 1.5V(minimum) to 6V(maximum). The RC network comprising of R1 and C1 provides the desired turn-on time delay. R3 & R4 is a voltage divider network to provide the required bias for Q2. R2 & R4 can be omitted when the input signal voltage is just enough to meet the minimum turn-on threshold of the switch.

When the 12Vin is first applied, Q2 is on and keeps the ON/Off pin to low. Since this is a positive Logic module, the output remains off.

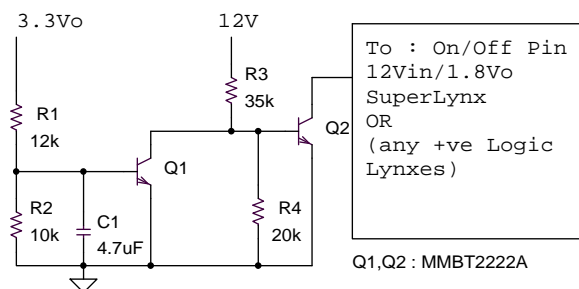

Fig. 3 Turn-on Interface Circuit for 3.3Vo to 1.8Vo SuperLynx (or any +ve LOGIC Devices).

When the 3.3Vo comes up, Q1 turns on after the desired delay (R1&C1). As soon as Q1 turns on, Q2 turns off and the module turns on due to the internal pull-up discussed earlier.

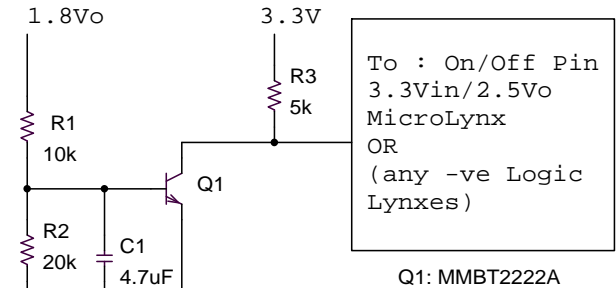

Fig. 4 Turn-on Interface Circuit for 1.8Vo to 2.5Vo MicroLynx (or any -ve LOGIC Devices).

Circuit Description: The turn-on input signal for this interface circuit is 1.8Vo derived from the output of the previous unit. The functionality and the requirements for R1, R2, C1 and Q1 are the same as described above. R3 is the pull up resistor.

When the 3.3Vin is first applied, the pull up resistor R3 pulls the on/Off pin high. Since this is a negative Logic module, the output remains off.

When the 1.8Vo comes up, Q1 turns on after the desired delay (R1&C1). As soon as Q1 turns on, the on/Off pin is pulled Low, turning the module on.

Test Results: The test data waveform in Fig. 5 shows that the desired sequencing objective was successfully accomplished. As soon as the +12Vin is applied, the 3.3Vo ramps up followed by 1.8Vo and the last module to turn on is the 2.5V. The time delay between the modules turning on was selected to be approximately 15 to 25 milliseconds.

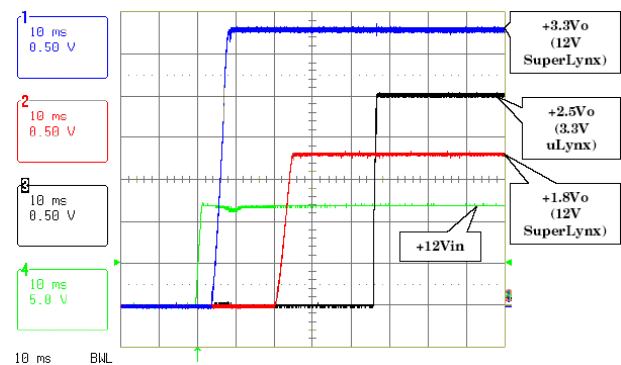

Fig. 5 Test Data

Layout Considerations

The following are recommended design guidelines when implementing the ON/Off control circuit:

- Locate On/Off components close to the module.
- Keep ground connections short.
- Minimize loop area.
- Add a small value (e.g. 100nF) decoupling capacitor in the presence of noisy ground.
- Beware of ground bounce (for mechanical control) during bench test or with manufacturing test fixtures.

Summary

The Remote ON/Off control feature is an invaluable tool that can be used in a variety of ways to control the proper turn on/off of the module. This application note discussed the types of On/Off controls and the design considerations for the successful implementation of the interface circuits that can be used for a successful system design. For additional related topics, also see **Application Note AN04-008** titled "**Application Guidelines for Non-Isolated Converters: Sequencing Recommendations**".



World Wide Headquarters
Lineage Power Corporation
601 Shiloh Road, Plano, TX 75074, USA
+1-800-526-7819
(Outside U.S.A.: **+1-972-244-9428**)
www.lineagepower.com
e-mail: techsupport1@lineagepower.com

Asia-Pacific Headquarters
Tel: +65 6593 7211

Europe, Middle-East and Africa Headquarters
Tel: +49 898 780 672 80

India Headquarters
Tel: +91 80 28411633

Lineage Power reserves the right to make changes to the product(s) or information contained herein without notice. No liability is assumed as a result of their use or application. No rights under any patent accompany the sale of any such product(s) or information.

Lineage Power DC-DC products are protected under various patents. Information on these patents is available at www.lineagepower.com/patents.

© 2009 Lineage Power Corporation, (Plano, Texas) All International Rights Reserved.